

Installation Instructions

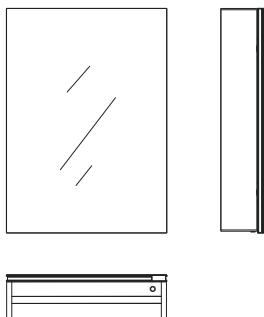
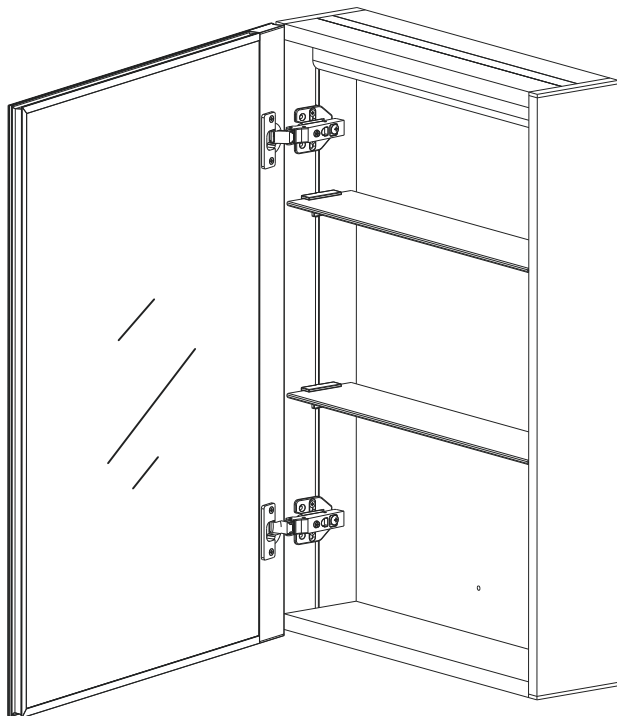

Wall Mounted Mirror Cabinet

- Adjustable stainless steel buffer hinge
- Double layer adjustable tempered glass shelf
- Infrared sensor switch
- Aluminum alloy cabinet
- Double-sided copper-free silver mirror

Note: This specification applies to Single door infrared induction switch LED Aluminum Cabinets.

Packing List

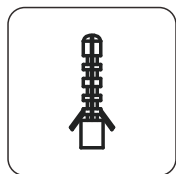

Expansion plug $\varnothing 8$

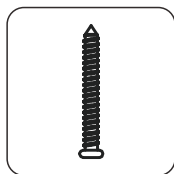

Screw M5

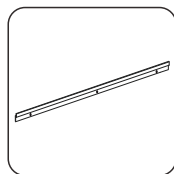

Aluminum alloy bar

Required tools

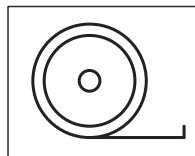

Tape measure

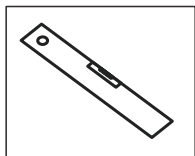

Spirit level

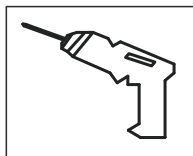

Electric drill

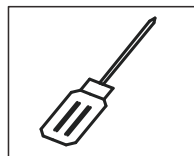

Screwdriver

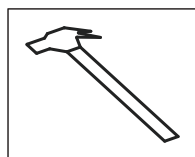

Hammer

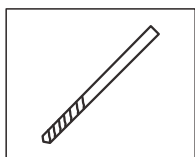

Drill bit

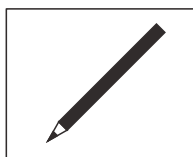

Pencil

Note: Please carefully read the following before installing



Warning

1. Before installing the product, please carefully read the instructions and operate accordingly;
2. Before installing, please turn off the main power switch and ensure that it won't turn on;
3. All electrical products should be fitted by a suitably qualified electrician in accordance with wiring regulations(BS7671)
4. This mirror cabinet is heavy; do not lift or install with single person in order to avoid injury;
5. Before installing, please check whether the product is broken, to avoid injury caused by damaged glass;
6. Do not clean the product surface with acid and alkaline cleaning agent; please use a damp cloth.
7. If the external flexible cable or cord of this luminaire is damaged, it shall be exclusively replaced by the manufacturer or his service agent or a similar qualified person in order to avoid a hazard.

Non-standard level

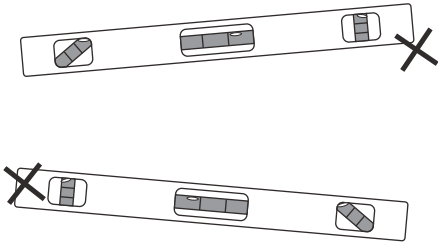

standard level

- 1 Look at the bubbles in the glass tube in the middle of the spirit level. The bubbles stay in the middle of the two black lines. It's horizontal.
- 2 Draw a straight line under the spirit level.
- 3 Place the Aluminum alloy bar on the drawn line, line up the hole position and punch the hole.

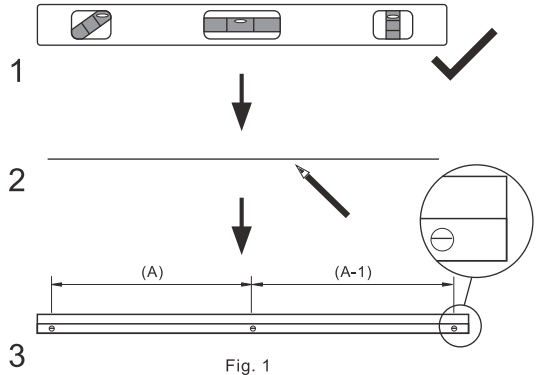

Fig. 1

Installation Steps:

1. Fixing the bar

- 1.1 Open the product packaging, and check whether the product has any exception or functional damage; if yes, please return it to the dealer.
- 1.2 After selecting the location of the mirror cabinet, check whether the wall is solid, measure the distance of the holes (A, A-1) in the aluminum alloy bar with a tape measure and mark it on the wall with a pencil (Fig. 1).
- 1.3 Drill holes in the marked position with electric drill with electric drill and $\varnothing 8$ drill bit, and use special ceramic drill if the wall surface is ceramic tile.
- 1.4 Knock the expansion plugs into the holes in the wall with a hammer, and then tighten the screws with a screwdriver to fix the bar, and calibrate the level with a spirit level (Fig. 2).

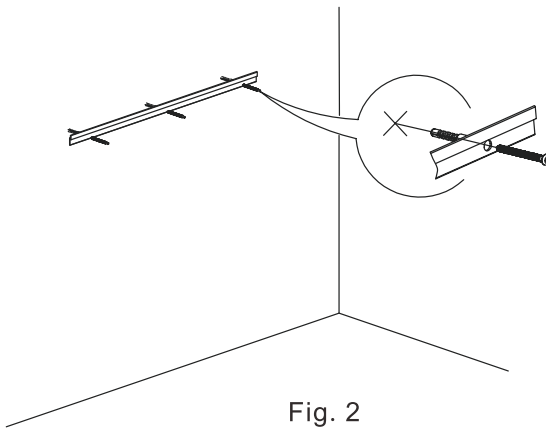

Fig. 2

③



2. Positioning and Installation of Mirror Cabinet:

- 2.1 Attach the mirror cabinet to the bar as shown in Fig. 3, open the cabinet door, and mark on the wall with a pencil (Fig. 4) through the backplane hole (a).
- 2.2 Remove the mirror cabinet, drill the fixing hole in the wall in the marked position, and place the expansion plugs (Fig. 5).
- 2.3 Repeat the operation as shown in Fig. 3 and mount the mirror cabinet to the bar, make sure that the circuit on the wall is not energized and connect the cabinet's power cord and reserved power cord with the terminal block (Fig. 6). And then tighten the screw on the hole (Fig. 6-b) to fix the cabinet.
- 2.4 Finally, turn on the main switch, and test if the switch works normally (Fig. 7).

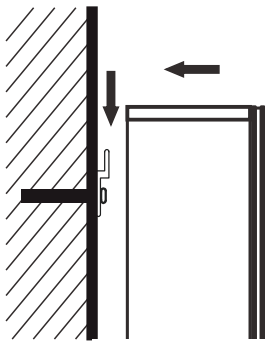

Fig. 3

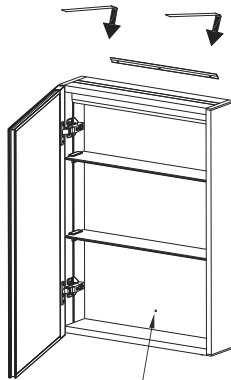

Fig. 4

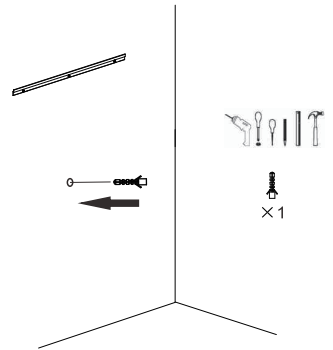

Fig. 5

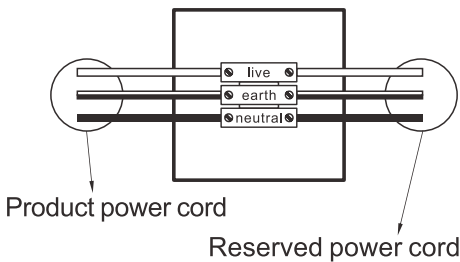
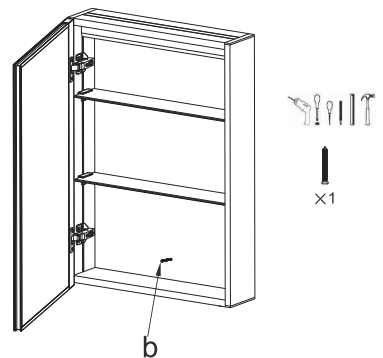

Fig. 6



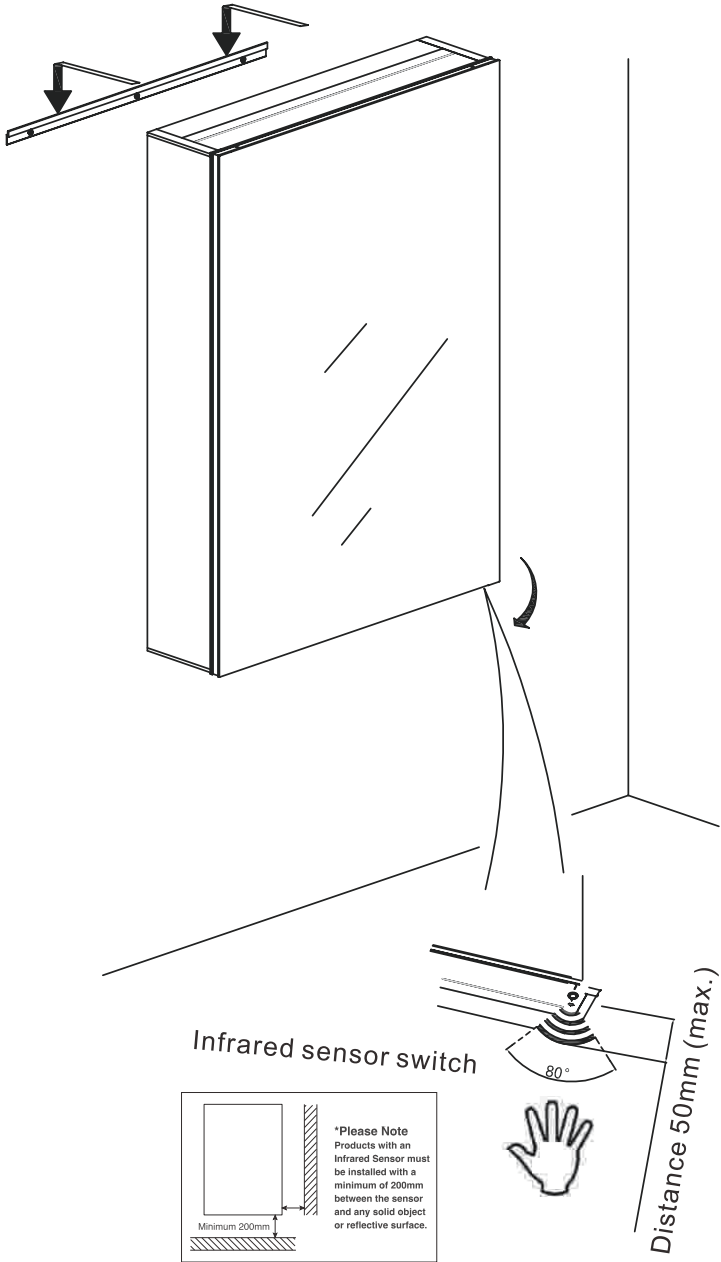

Fig. 7

3. Mirror Door Adjustment

3.1 Fix the mirror cabinet, and check if the mirror door is flat; if not (as shown in Fig. 8), adjust the distance of the door opening by adjusting the hinge screw (b) and keep the door level (Fig. 9).

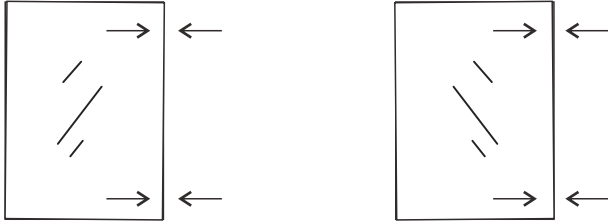
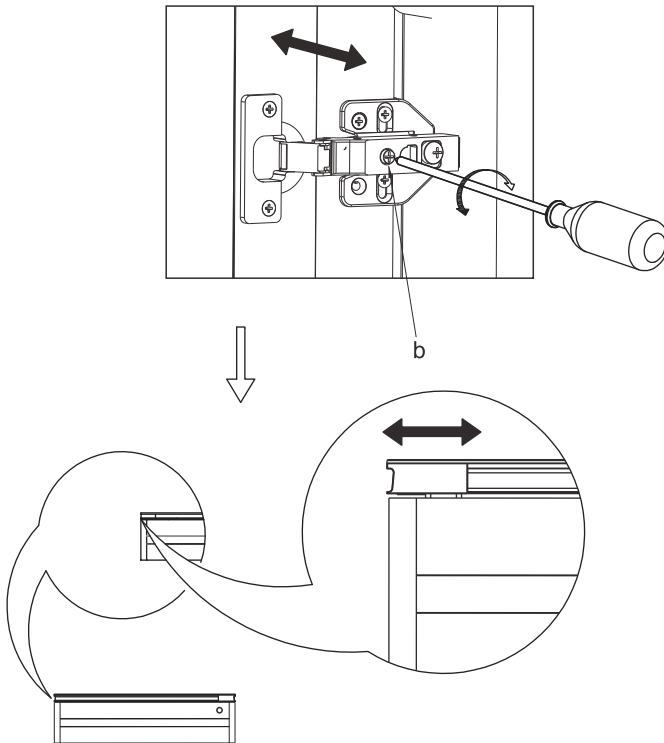

Fig. 8



Rotate CW: Door moves to the center of the mirror cabinet
Rotate CCW: Door moves to both sides of the mirror cabinet

Fig. 9

3.2 If the cabinet door isn't flat (Fig. 10), adjust the distance between the door and the cabinet by adjusting the screw (c) to make the door flat. (Fig. 11)

⚠ Warning: The distance between the door and the cabinet should not be too small, otherwise the door can't be opened and may lead to the door rupture.

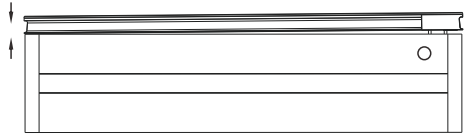
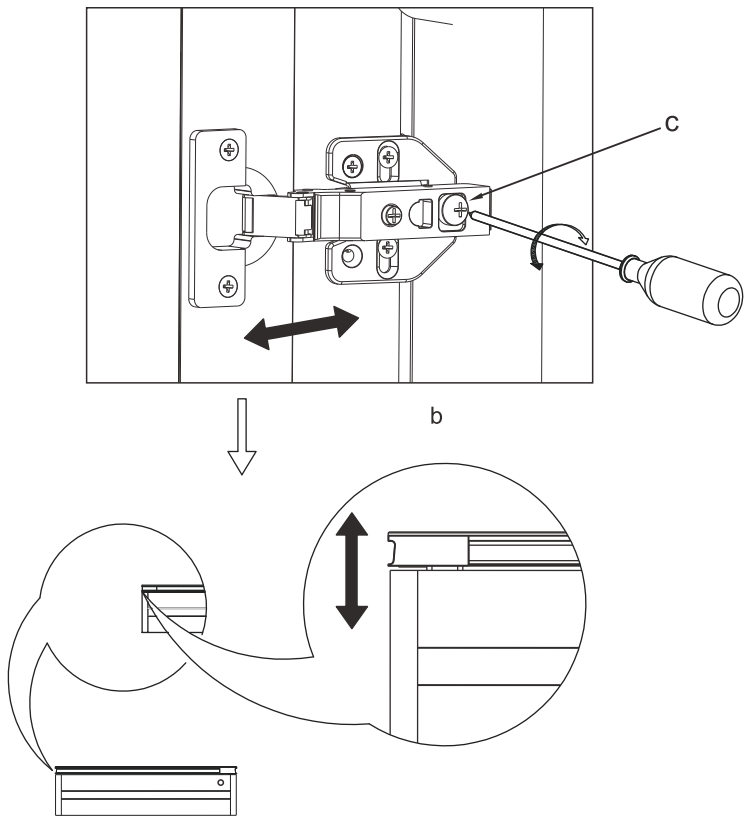

Fig. 10



Rotate CW: Distance between door and cabinet reduces
Rotate CCW: Distance between door and cabinet increases

Fig. 11

4. Loosen the snap screw (d) of the shelf to adjust the shelf position.
(Fig.12)

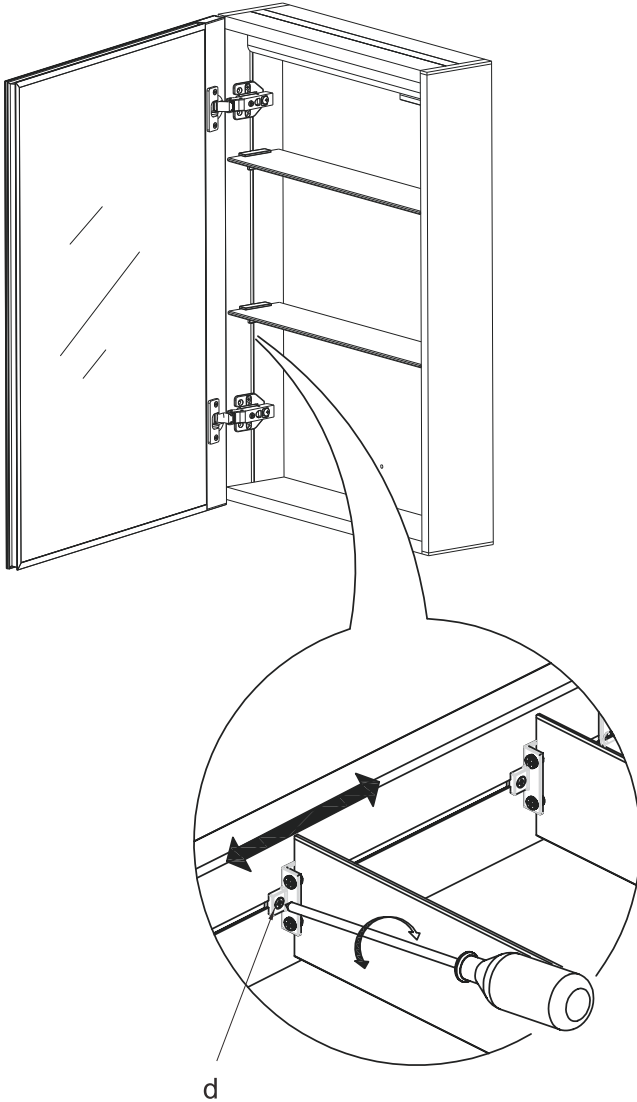

Safety Warning

Fig. 12

- Do not disassemble the door unless necessary